

## MIT Hygienic Centrifugal Pump Schedule

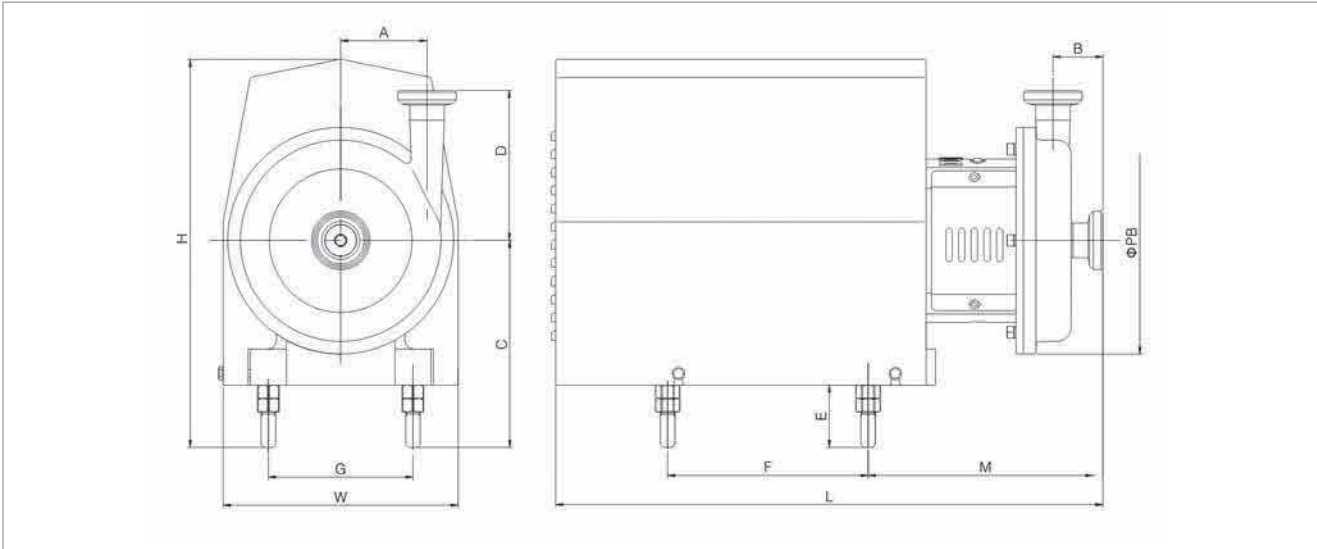

Model	Motor kW			PB	ø	A	B	C	D	M	F	G	H	L	W	E	C	H	E
MP-10	1,5	1,5"	1,5"	189	32	63	60	190	136	163	240	140	360	528	210	70	222	392	102
	2,2	1,5"	1,5"	189	32	63	60	210	136	163	240	140	360	528	210	70	242	392	102
MP-15	1,5	2"	1,5"	250	32	90,5	42	190	155	186	240	140	360	551	210	70	222	392	102
	2,2	2"	1,5"	250	32	90,5	42	210	155	186	240	140	360	551	210	70	242	392	102
MP-20-I MP-20-II	2,2	2"	2"	250	32	85	45	210	170	186	240	140	360	551	210	70	242	392	102
	3	2"	2"	250	32	85	45	230	170	175	300	160	430	599	260	70	262	462	102
	4	2"	2"	250	32	85	45	222	170	175	300	190	430	599	260	70	254	462	102
	5,5	2"	2"	250	32	85	45	252	170	197	330	216	470	737	310	70	284	502	102
MP-25	4	2"	1,5"	268	32	108	56	222	190	173	300	190	430	597	260	70	254	462	102
	5,5	2"	1,5"	268	32	108	56	252	190	195	330	216	470	735	310	70	284	502	102
MP-30	5,5	2"	1,5"	268	32	108	56	252	190	195	330	216	470	735	310	70	284	502	102
	7,5	2"	1,5"	268	32	108	56	252	190	195	330	216	470	735	310	70	284	502	102
MP-35-I	11	2,5"	1,5"	350	36	131	68	290	229	240	450	254	575	860	375	102	322	607	102
	15	2,5"	1,5"	350	36	131	68	290	229	240	450	254	575	860	375	102	322	607	102
MP-35-II	15	2,5"	2"	350	36	131	68	290	229	240	450	254	575	860	375	102	322	607	102
	18,5	2,5"	2"	350	36	131	68	290	229	240	515	254	575	885	375	102	322	607	102
MP-40-I MP-40-II	11	3"	2,5"	303	36	105	73,5	290	213,5	240	450	254	575	870	375	102	322	607	102
	15	3"	2,5"	303	36	105	73,5	290	213,5	240	450	254	575	870	375	102	322	607	102
	18,5	3"	2,5"	303	36	105	73,5	290	213,5	240	515	254	575	895	375	102	322	607	102
	22	3"	2,5"	303	36	105	73,5	310	213,5	240	515	279	625	946	400	102	342	657	102
	30	3"	2,5"	303	36	105	73,5	330	213,5	267	580	318	670	1014	440	102	362	702	102

## Performance Curve

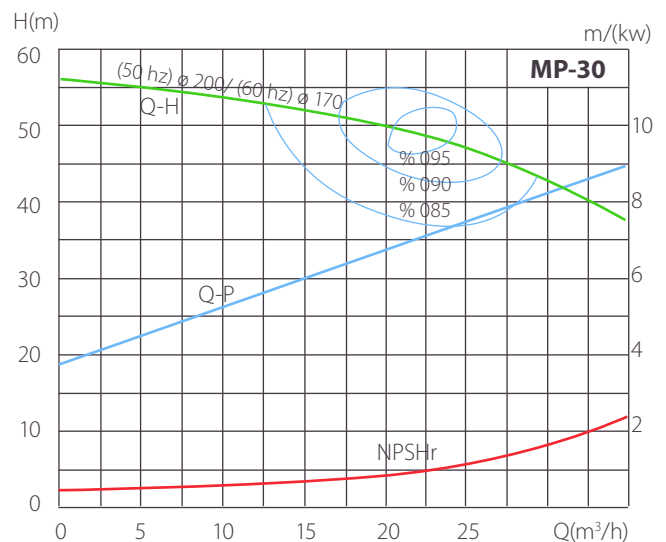
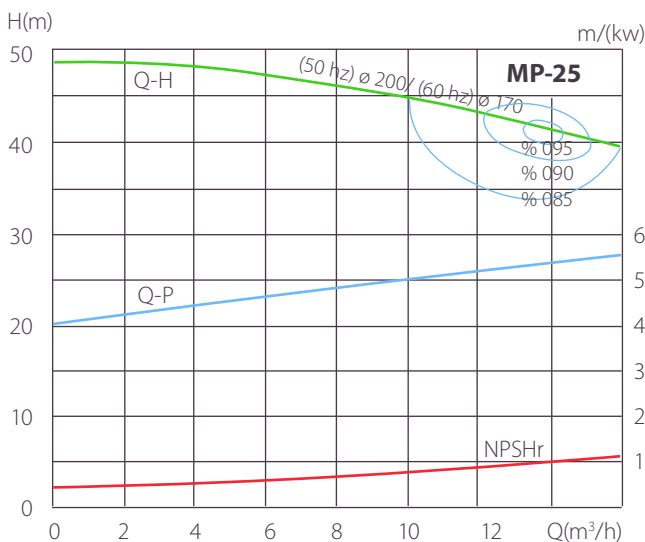
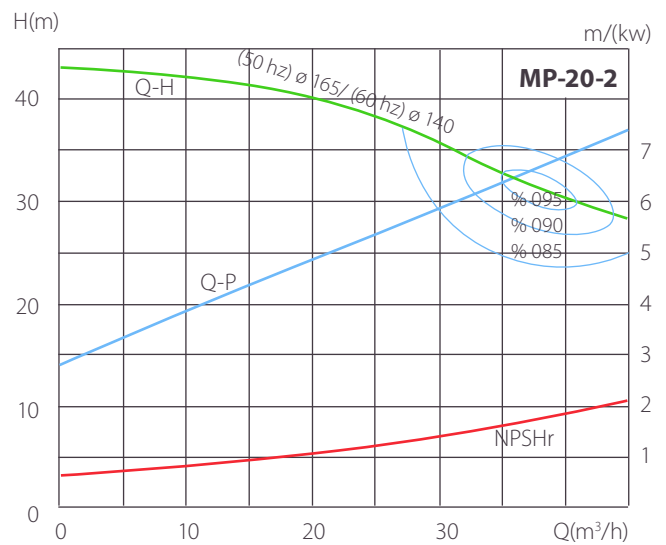
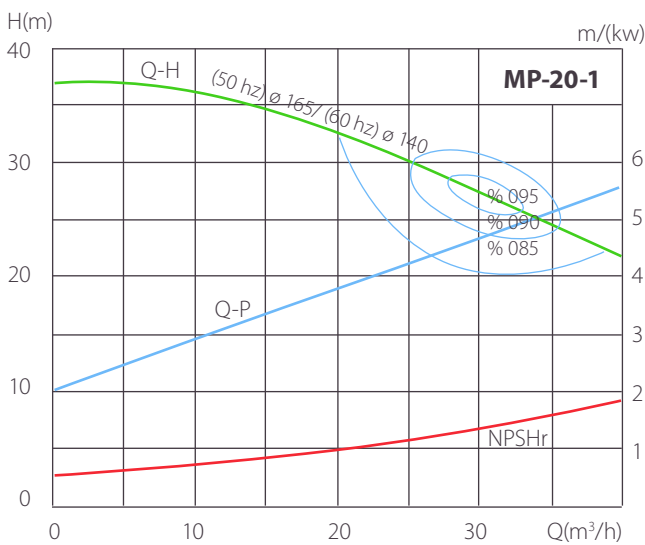
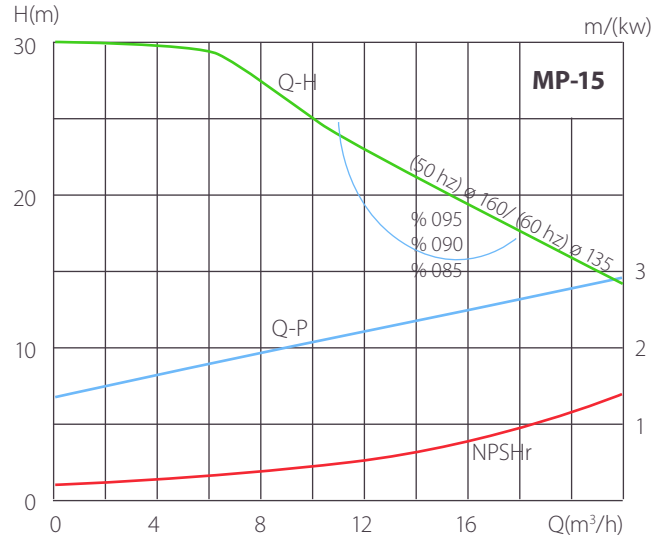
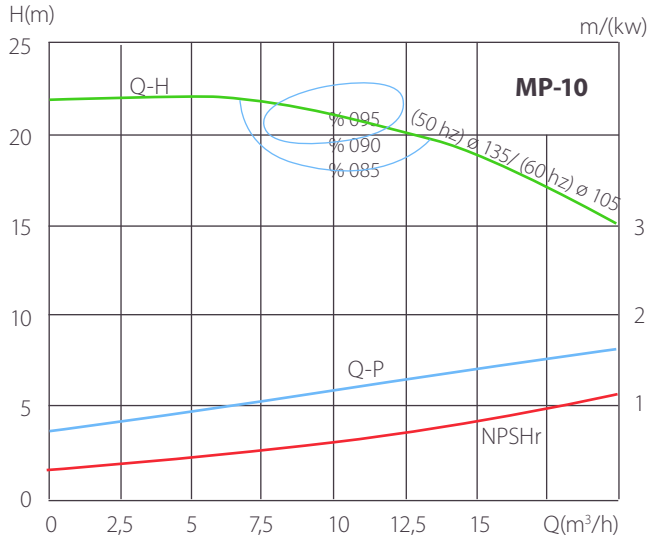

## Performance Curve

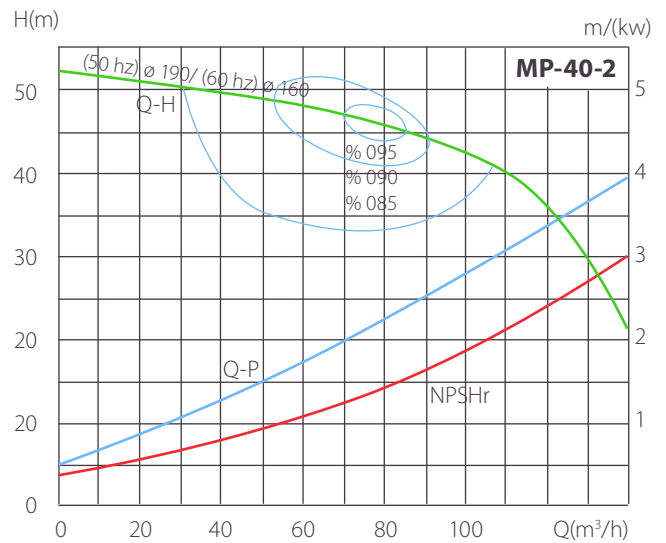
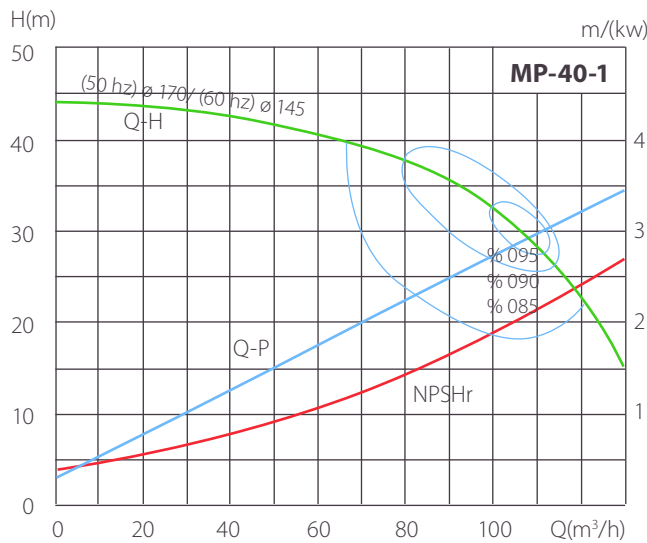
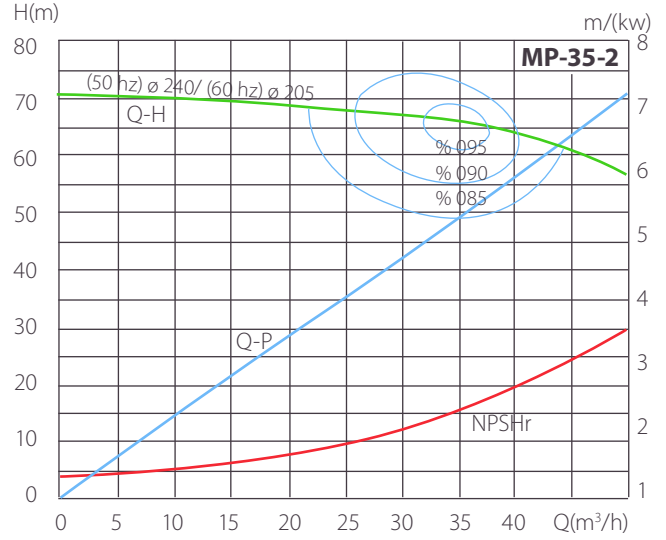
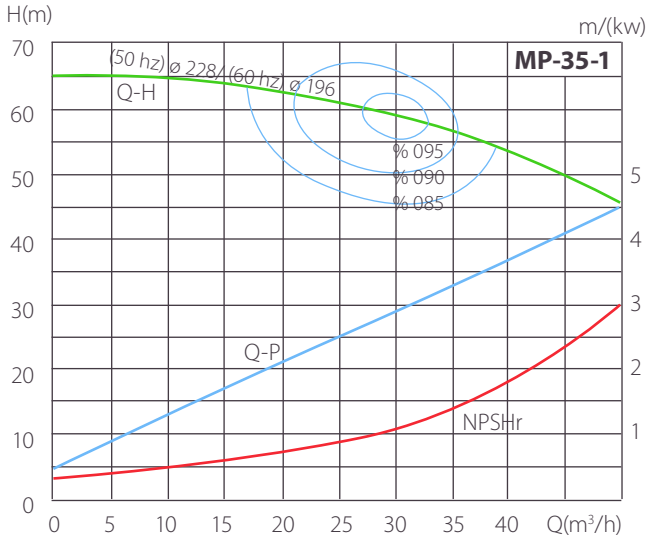

## Optional Features

MIT hygienic centrifuge pumps can be produce in various options.

It can be easily used on a wheeled chassis portably and with adding a control panel to this chassis.

Only thing here is to connect the control panel to a power grid.

